

www.jitool.com

Rev. Mar. 2017

JITOOOL

HEADQUARTERS

18 Jikdong-ro, Gwangju-si,
Gyeonggi-do, Korea
TEL : +82-2-445-2500
FAX : +82-2-445-2506
E-mail : jitool@jitool.com

JITOOOL USA CORP.

14404 Iseli Road,
Santa Fe Springs, CA 90670, USA
TEL : +1-562-404-8740
FAX : +1-562-404-8490

JITOOOL



[CATALOG]

Manufactured, Assembled & Inspected from our own factory.

www.jitool.com

ABOUT US

Better Tool, Better Works! **JITOOL**

JITOOL has been a leading manufacturer of pneumatic tools as nailer and stapler in Korea.

With more than 30 years of experience, JITOOL believes that we have come together with latest technology and customer focus.

JITOOL constantly making efforts to become 'World-class corporation'.

To achieve this vision, we continuously R&D and improve the quality of products.

We have been developing state-of-the-art products and also satisfying global customers by providing best quality service.

With ongoing innovation, JITOOL will proceed to become a global leader.

◆ Pneumatic Tools

- Nailer • Stapler • Pinner • Punch • C-ringer
- Coil & Brad Nail - Strip Nail - Staple - Micro Pin



JITOOL KOREA (FIRST)
JITOOL Factory for Tool



JITOOL KOREA (SECOND)
JITOOL Factory for Fastener

Company History

www.jitool.com

- 1983 - Established Jeil Tacker Co., Ltd.
Produced Air Tacker (Nailer & Stapler)
- 1984 - Developed Air Tacker 3 Items (1013J, 413J, 422J)
- 1985 - Developed Air Tacker 5 Items (F30, 1022J, F-50, F-64, 618)
- 1987 - Developed Air Tacker 4 Items (938, 951, 722, MA438)
- 1990 - Developed Air Tacker 3 Items (CT64, 1150, 1832)
- 1994 - Developed Air Tacker 4 Items (NT64, PF25, JN-501, JN830)
- 1998 - Became a member of The STAFDA (U.S.A.)
Developed Air Tacker 5 Items (1565, JS16, AP35, AP64, JN650)
- 1999 - Certified for CE
Developed Air Tacker 2 Items (JS16-54, JN650)
- 2000 - Attended The STAFDA Show (every year)
A Founded Second Factory- Produced Staple
Acquired KSA / ISO 9001 Certification
Developed Air Tacker 3 Items (9032, 1665, 1651)
- 2001 - Developed Air Tacker 3 Items (9038A, 1651S, FN2190)
- 2002 - Second Factory Plant expansion (Produced Brad Nails)
- 2003 - Developed Air Tacker 2 Items (1651PW, 630)
- 2004 - Developed Air Tacker 1 Items (CT64N)
- 2005 - Developed Air Tacker 2 Items (JN45R, JN2190)
- 2006 - INNO BIZ
The Certificate of Venture Business
Developed Air Tacker 3 Items (JNS45, 640, JPS38R)
- 2007 - Relocated First Factory
Developed Air Tacker 3 Items (JS16-80, 1850A, JPS38)
- 2008 - Established JITOOL USA Co. in California, U.S.A.
Developed Air Tacker 3 Items (JN70C, T64R, T50)
- 2009 - Developed Air Tacker 4 Items (JN55C, JLS38, TRS25S, TRS25B)
- 2010 - Developed Air Tacker 3 Items (AP64R, 1013F, JS16-34M)
- 2011 - Developed Air Tacker 2 Items (JN100C, JN80C)
- 2012 - Developed Air Tacker 5 Items (CS26/38, FN21/90, FN34/90, TRS38S, S740/18)
- 2013 - Developed Air Tacker 5 Items (CS15/50, CS26/64, JN65S, BN16/50, BN16/64)
- 2014 - Developed Air Tacker 4 Items (IN160, JN50C, S80/16-20, S71/16-22)
- 2015 - Developed Air Tacker 5 Items (IN220, 630R, CT64R3, S850/16, S950/16)
- 2016 - Developed Air Tacker 4 Items (JQS65, JS440K, JC7, JC7C)
- 2017 - Developed Air Tacker 2 Items (S10/13, JC760)



KOREA

JITOOOL KOREA.
18 Jikdong-ro, Gwangju-si,
Gyeonggi-do, Korea

Tel : +82-2-445-2500
Fax : +82-2-445-2506

USA

JITOOOL USA CORP.
14404 Iseil Road,
Santa Fe Springs, CA 90670

Tel : +1-562-404-8740
Fax : +1-562-404-8490

CHINA

TIANJIN JITOOOL Co.Ltd
No3. Tianyong street, Liutan Industrial,
Tiedong Road, Beichen District,
Tianjin, China

Tel : +86-22-8694-3162
Fax : +86-22-8685-3161



CONTENTS

Company History _ 03

Global Network_ 04

C-Ringer _ 06

Nailer _ 08

Coil Nailer _ 13

Stapler_ 16

Pinner _ 25

Punch_ 26

Compressor_ 27

C-RINGER

JITOOOL C-Ringer series
30th Anniversary fastening system



Mattress



Car seat performance



Fabric, Jute Netting

JC7C

15GA. C-Ringer

• **Weight :**

- 1.54 kg(3.4 lbs)

• **Dimensions :**

- H : 13-7/16" (342mm)

- L : 7-3/8" (187mm)

- W : 3-1/2"(89mm)

• **Ring Capacity**

- 130

• **Applications :**

- Automotive Seat
- Mattress
- Fence Connection



• **Fasteners :**

- MEIHO : M-6CAW
- BOSTITCH : SC7C

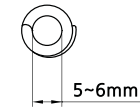
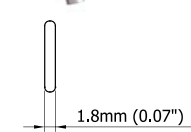
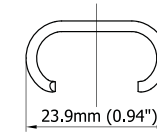

JC7

15GA. C-Ringer

• **Weight :**

- 1.54 kg(3.4 lbs)

• **Dimensions :**

- H : 13-7/16" (342mm)

- L : 7-3/8" (187mm)

- W : 3-1/2" (89mm)

• **Ring Capacity**

- 130

• **Applications :**

- Automotive Seat
- Mattress
- Fence Connection



• **Fasteners :**

- MEIHO : M-6W
- BOSTITCH : SC7

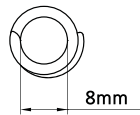
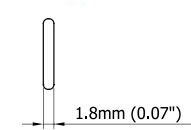
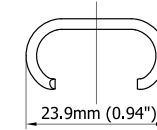

JC7E

15GA. C-Ringer

• **Weight :**

- 1.6 kg(3.5 lbs)

• **Dimensions :**

- H : 14-1/16" (357mm)

- L : 7-3/8" (187mm)

- W : 3-1/2" (89mm)

• **Ring Capacity**

- 130

• **Applications :**

- Automotive Seat
- Mattress
- Wire Mesh Products
- Fence Connection



• **Fasteners :**

- MEIHO : M-6LW
- BOSTITCH : SC7E

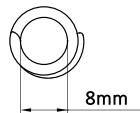
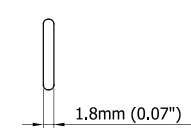
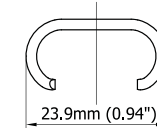

CS26/38

Air Concrete Nailer

• **Weight :**

- 3.69 kg (8.1 lbs)

• **Dimensions :**

- H : 13-3/4" (349mm)
 - L : 18-1/4" (464mm)
 - W : 4-5/8" (117mm)

• **Fasteners :**

- MAX : GS638E

• **Nail Capacity :**

- 42 Nails

• **Applications :**

- Drywall track to concrete/steel
 - Concrete furring
 - Wood to steel



• Magnesium Body

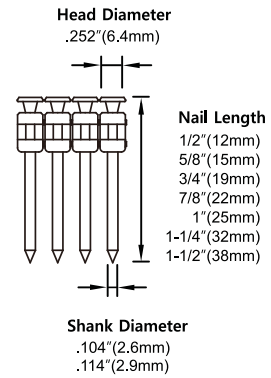

CS15/50

15GA. Mini Concrete Nailer

• **Weight :**

- 1.72kg (3.8 lbs)

• **Dimensions :**

- H : 10-5/8" (268mm)
 - L : 11-7/16" (290mm)
 - W : 3" (75.5mm)

• **Fasteners :**

- BEA : SKS600
 - YOUNGWOOD : FST15/50

• **Nail Capacity :**

- 100 Nails

• **Applications :**

- For plinth and frame work
 - Interior and building finishing
 - Light steel connections



• Magnesium Body

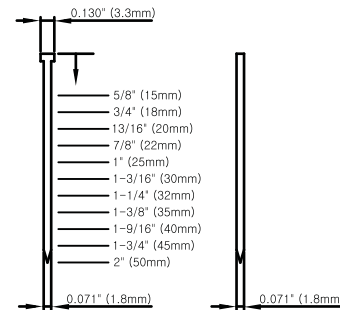

CS26/64

Air Concrete Nailer

• **Weight :**

- 3.86 kg(8.5 lbs)

• **Dimensions :**

- H : 14-7/16" (367mm)
 - L : 18-3/8" (466.2mm)
 - W : 4-7/8" (123mm)

• **Fasteners :**

- MAX : GS638E

• **Nail Capacity :**

- 42 Nails

• **Applications :**

- Drywall track to concrete/steel
 - Concrete furring
 - Wood to steel
 - Sill plate to concrete



• Magnesium Body

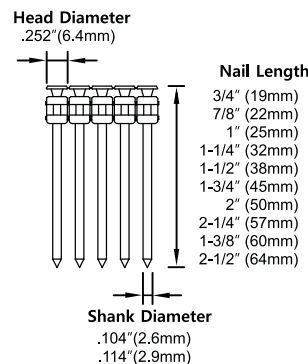

FN21/90

21° Full Round Head Framing Nailer

• **Weight :**

- 3.8 kg(8.4 lbs)

• **Dimensions :**

- H : 13-11/32" (339mm)
 - L : 19-11/16" (500mm)
 - W : 4-1/2" (114mm)

• **Nail Capacity :**

- 64 Nails

• **Applications :**

- Framing
 - Truss building
 - Subflooring
 - Sheathing and Decking
 - Crating and Pallets
 - Fencing



• Magnesium Body

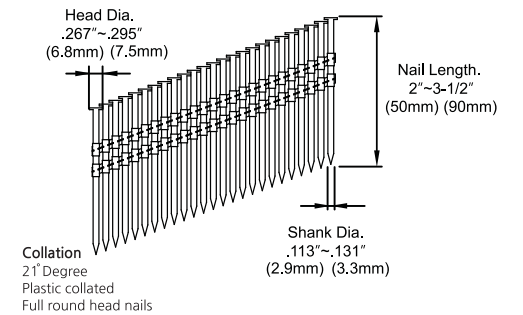

FN34/90

34° Clipped Head Framing Nailer

• **Weight :**

- 3.8 kg(8.4 lbs)

• **Dimensions :**

- H : 13-25/32" (350mm)
 - L : 17-9/16" (446mm)
 - W : 4-1/2" (114mm)

• **Nail Capacity :**

- 90 Nails

• **Applications :**

- Framing
 - Truss building
 - Subflooring
 - Sheathing and Decking
 - Crating and Pallets
 - Fencing



• Magnesium Body

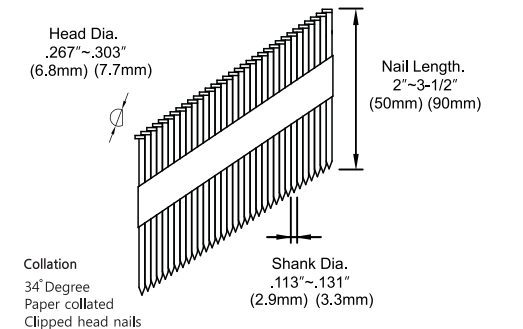

JN2190

21° Full Round Head Framing Nailer

• **Weight :**

- 3.9 kg(8.6 lbs)

• **Dimensions :**

- H : 14" (356mm)
 - L : 19-8/9" (505mm)
 - W : 4-6/7" (123mm)

• **Nail Capacity :**

- 64~70 Nails

• **Applications :**

- Pallets
 - Crate & Box Assembly
 - Framing
 - Sheathing and Decking
 - Subflooring



• Magnesium Body

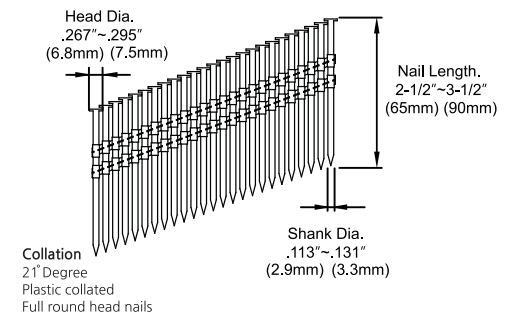

• **Fasteners :**

- BOSTITCH : N Series
 - MAX : SN Series
 - SENCO : FramePro Series
 - HITACHI : NR83A Series

• **Fasteners :**

- BOSTITCH : N Series
 - MAX : SN Series
 - SENCO : FramePro Series
 - HITACHI : NR83AA Series

• **Fasteners :**

- BOSTITCH : N Series
 - MAX : SN Series
 - SENCO : FramePro Series
 - HITACHI : NR90 Series

CT64R3

14GA. 64mm Brad & Concrete Nailer

• **Weight :**

- 2.47 kg(5.44 lbs)

• **Dimensions :**

- H : 12-3/16" (310mm)
 - L : 12-7/16" (316mm)
 - W : 4" (101mm)

• **Nail Capacity :**

- 80 Nails

• **Applications :**

- Window & Door Molding
 - Cabinet Furniture Trim
 - Trusses Building
 - Wood to Concrete



• Magnesium Body

• **Fasteners :**

- PASLODE : 3250-F14
 404677 Series

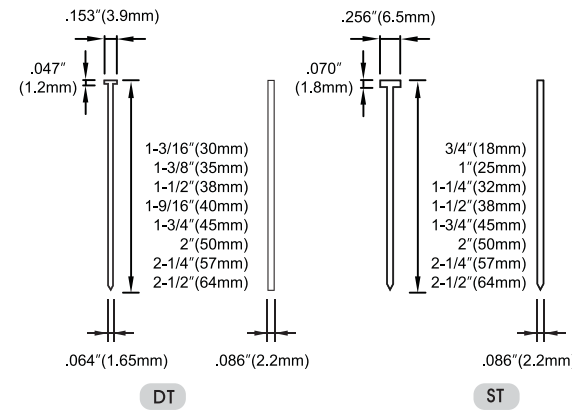

IN160

Insulation Nailer

• **Weight :**

- 3.4 kg(7.5 lbs)

• **Dimensions :**

- H : 12-7/8" (328mm)
 - L : 17-11/16" (449mm)
 - W : 4-13/16" (123mm)

• **Nail Capacity :**

- 1 Nail

• **Operating Pressure :**

- 85~120psi(6~8kgf/cm²)

• **Applications :**

- Fix the insulation layer on the concrete and brick



• Magnesium Body

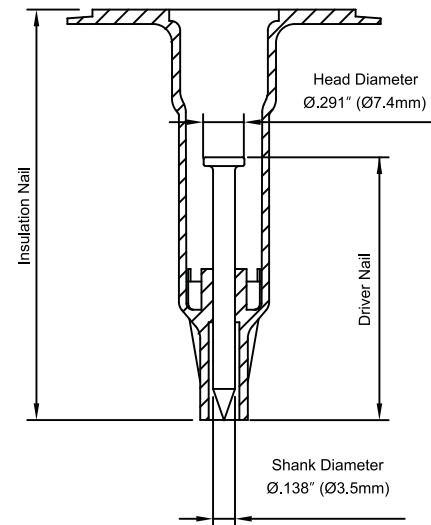

Insulation Nail Length	Driver Nail Length
1-3/16" (30mm)	1-5/8" (42mm)
1-3/8" (35mm)	
1-9/16" (40mm)	
1-3/4" (45mm)	2-1/16" (52mm)
2" (50mm)	
2-3/8" (60mm)	
2-3/4" (70mm)	
3-3/16" (80mm)	
3-9/16" (90mm)	
3-15/16" (100mm)	
4-3/4" (120mm)	
5-1/2" (140mm)	
5-7/8" (150mm)	
6-5/16" (160mm)	
7-1/16" (180mm)	
7-7/8" (200mm)	
8-11/16" (220mm)	

IN220

Insulation Nailer

• **Weight :**

- 3.5 kg(7.7 lbs)

• **Dimensions :**

- H : 12-7/8" (328mm)
 - L : 20-1/16" (509mm)
 - W : 4-13/16" (123mm)

• **Nail Capacity :**

- 1 Nail

• **Operating Pressure :**

- 85~120psi(6~8kgf/cm²)

• **Applications :**

- Fix the insulation layer on the concrete and brick



• Magnesium Body

BN16/50

16GA. Finish Nailer

• **Weight :**

- 1.72kg (3.8 lbs)

• **Dimensions :**

- H : 10-5/8" (268mm)
 - L : 11-1/4" (286mm)
 - W : 3" (75.5mm)

• **Nail Capacity :**

- 100 Nails

• **Fasteners :**

- BEA : SK400 Series
 - HITACHI : 142 Series
 - POTER CABLE : FN16 Series

• **Applications :**

- Molding & Decorative Trim
 - Furniture Trim
 - Door & Window Casings
 - Component Assembly
 - Picture Frame Assembly



• Magnesium Body

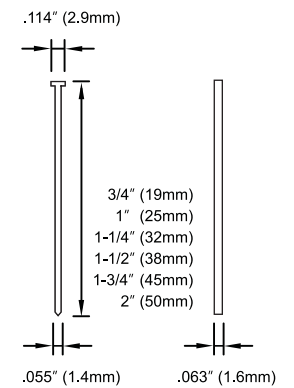

www.jitool.com

BN16/64

16GA. Finish Nailer

• **Weight :**

- 1.78kg (3.92 lbs)

• **Dimensions :**

- H : 11-1/8" (282mm)
 - L : 11-1/4" (286mm)
 - W : 3" (75.5mm)

• **Nail Capacity :**

- 100Nails

• **Fasteners :**

- BEA : SK400 Series
 - HITACHI : 142 Series
 - POTER CABLE : FN16 Series

• **Applications :**

- Molding & Decorative Trim
 - Furniture Trim
 - Door & Window Casings
 - Component Assembly
 - Picture Frame Assembly



• Magnesium Body

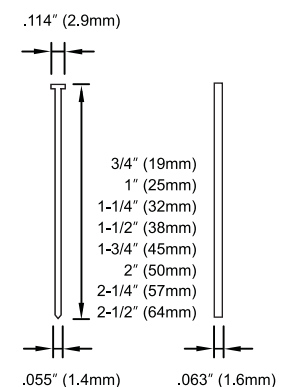

1850A

18GA. 50mm Brad Nailer

- **Weight :**
 - 1.39kg (3.06 lbs)
- **Dimensions :**
 - H : 9-5/8" (244mm)
 - L : 9-5/8" (244mm)
 - W : 2-5/16" (62mm)
- **Nail Capacity :**
 - 100 Nails
- **Fasteners :**
 - MAX : NF255-ST/18 Series
 - HITACHI : NT Series
- **Applications :**
 - Molding & Decorative Trim
 - Mirror & Picture Frames
 - Case Backs
 - Interior Trim & Exterior Trim

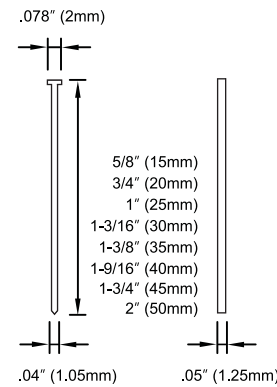

www.jitool.com

F30

18GA. 30mm Brad Nailer

- **Weight :**
 - 1.1kg (2.42 lbs)
- **Dimensions :**
 - H : 7-7/16" (189mm)
 - L : 9-11/32" (239mm)
 - W : 2-3/8" (60mm)
- **Nail Capacity :**
 - 100 Nails
- **Fasteners :**
 - MAX : TA20A Series
 - HITACHI : NT Series
- **Applications :**
 - Molding & Decorative Trim
 - Furniture Trim
 - Interior Trim & Exterior Trim

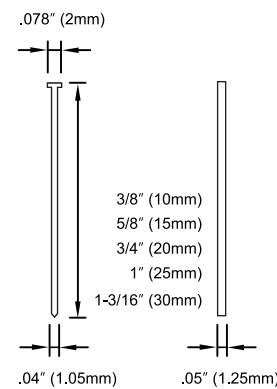

JN80C

Industrial Coil Nailer

- **Weight :**
 - 3.76 kg(8.3 lbs)
- **Dimensions :**
 - H : 13-7/8" (353mm)
 - L : 12-1/16" (306mm)
 - W : 5-3/8" (137mm)
- **Nail Capacity :**
 - 1Roll (250~300 pcs)
- **Fasteners :**
 - HITACHI : NV83 Series
 - MAX : CN80 Series
- **Applications :**
 - Making and Repairing wooden pallets and boxes
 - All Types of packing and crating
 - Fencing, framing, roof decking, flooring



• Magnesium Body

15 Degree Flat Wire Welded Nails
Head Diameter $\varnothing 224'' \sim \varnothing 283''$
($\varnothing 5.7\text{mm} \sim \varnothing 7.2\text{mm}$)

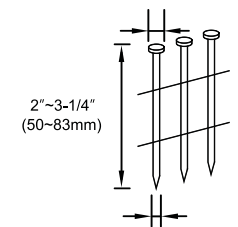

Shank Diameter $\varnothing 099'' \sim \varnothing 131''$
($\varnothing 2.5\text{mm} \sim \varnothing 3.3\text{mm}$)

www.jitool.com

JN100C

Industrial Coil Nailer

- **Weight :**
 - 5.6 kg(12.4 lbs)
- **Dimensions :**
 - H : 15-15/16" (405mm)
 - L : 14-7/8" (378mm)
 - W : 6" (153mm)
- **Nail Capacity :**
 - 1Roll (200~250 pcs)
- **Fasteners :**
 - MAX : CN100 Series
- **Applications :**
 - Making wooden pallets
 - Heavy duty wooden boxes
 - Crating
 - Packaging



15 Degree Flat Wire Welded Nails
Head Diameter $\varnothing 276'' \sim \varnothing 295''$
($\varnothing 7.0\text{mm} \sim \varnothing 7.5\text{mm}$)

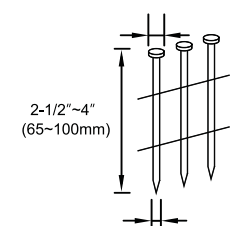

Shank Diameter $\varnothing 113'' \sim \varnothing 131''$
($\varnothing 2.9\text{mm} \sim \varnothing 3.3\text{mm}$)

JN65S

Siding Coil Nailer

Weight :

- 2.1kg(4.6 lbs)

Dimensions :

- H : 12" (305mm)
 - L : 10-11/32" (263mm)
 - W : 5-5/16" (134mm)

Nail Capacity :

- 1Roll (200~300 pcs)

Fasteners :

- BOSTITCH : N66C
 - MAX : CN565S
 - HITACHI : NV65AH

Applications :

- General construction works including siding
 - Decking
 - Panel sheathing



• Magnesium Body

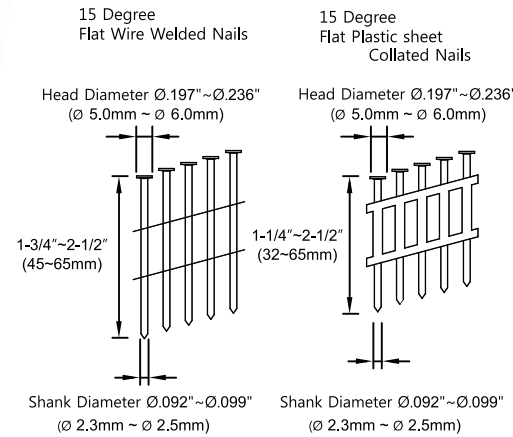

JN50C

Industrial Coil Nailer

Weight :

- 2.05kg(4.5 lbs)

Dimensions :

- H : 10-1/2" (267mm)
 - L : 10-11/32" (263mm)
 - W : 4-13/16" (122mm)

Nail Capacity :

- 1Roll (400 pcs)

Fasteners :

- HITACHI : NV50A1

Applications :

- Making wooden crate
 - Fencing
 - Making and Repairing Pallets
 - Siding, Decking and Sheathing



• Magnesium Body

15 Degree Dome Wire Welded Nails

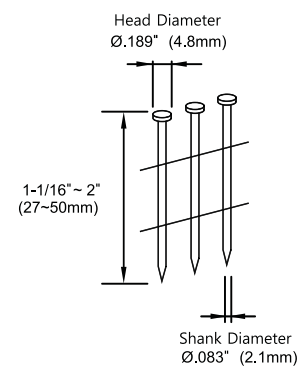

JN45R

Roofing Coil Nailer

Weight :

- 2.26 kg(4.98 lbs)

Dimensions :

- H : 10-1/2" (267mm)
 - L : 10-1/2" (267mm)
 - W : 4-7/16" (113mm)

Nail Capacity :

- 120 Nails

Applications :

- Siding Installation
 - Wooden Box Assembly
 - Fastening asphalt & fiberglass shingles



• Magnesium Body

Fasteners :

- HITACHI : NV45 Series
 - BOSTITCH : RN45B, RN46
 - MAX : CN450R, CN445R
 - SENCO : RoofPro Series

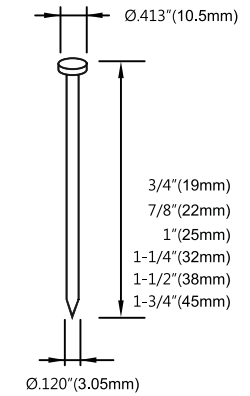

JN55C

Industrial Coil Nailer

Weight :

- 2.63 kg(5.8 lbs)

Dimensions :

- H : 10-19/32" (269mm)
 - L : 10-3/4" (273mm)
 - W : 5-5/16" (135mm)

Nail Capacity :

- 1Roll (300~400 pcs)

Applications :

- Making wooden crate
 - Fencing
 - Making and Repairing Pallets
 - Siding, Decking and Sheathing



Fasteners :

- BOSTITCH : N57C
 - MAX : CN55 Series
 - SENCO : PalletPro 57F

15 Degree Flat Wire Welded Nails
 Head Diameter 0.197"~0.244"
 (0 5.0mm ~ 0 6.0mm)

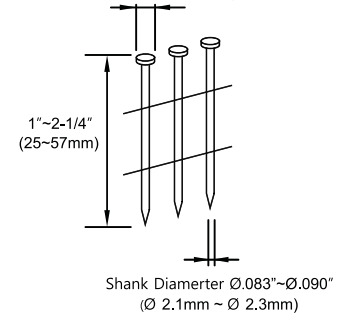

JN70C

Pallet Coil Nailer

Weight :

- 3.48 kg(7.67 lbs)

Dimensions :

- H : 12-1/2" (317mm)
 - L : 13-3/32" (333mm)
 - W : 5-5/16" (135mm)

Nail Capacity :

- 1Roll (250~300 pcs)

Applications :

- Making wooden crate
 - Fencing
 - Making and Repairing Pallets
 - Siding, Decking and Sheathing



• Magnesium Body

Fasteners :

- HITACHI : NV65 Series
 - BOSTITCH : N70 Series
 - MAX : CN70 Series
 - PASLODE : P275C/F275C Series

15 Degree Flat Wire Welded Nails
 Head Diameter 0.224"~0.283
 (0 5.7mm ~ 0 7.2mm)

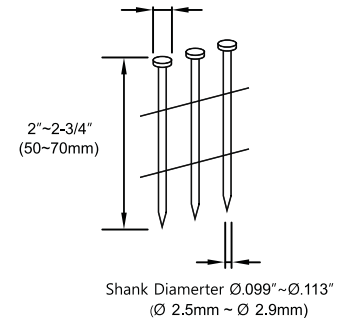

JNS45

16GA.7/16" Medium Crown Stapler

● **Weight :**

- 2.22 kg (4.9 lbs)

● **Dimensions :**

- H : 11-3/4" (298mm)
 - L : 13-3/4" (349mm)
 - W : 3-11/16" (94mm)

● **Staple Capacity :**

- 160 staples

● **Applications :**

- Sheathing & Subflooring
 - Roof Decking
 - Furniture & Pallets
 - Crate & Wooden box



● **Fasteners :**

- MAX : TA551 Series
 - HITACHI : N5008AC/11200 Series
 - SENCO : SNS45XP/N Series

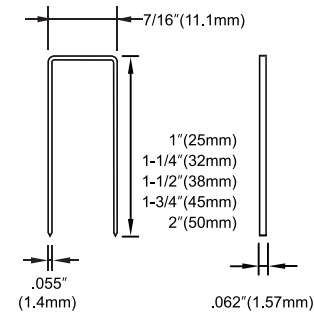

JPS38R

16GA.1" Wide Crown Stapler

● **Weight :**

- 2.40 kg (5.3 lbs)

● **Dimensions :**

- H : 10-3/8" (263mm)
 - L : 14-7/16" (367mm)
 - W : 3-17/32" (90mm)

● **Staple Capacity :**

- 160 staples

● **Applications :**

- Fastening asphalt & fiberglass
 Roof shingles
 - Construction
 - Wooden working-furniture,
 Box Assembly



● Magnesium Body

● **Fasteners :**

- SENCO : PW150R/P Series
 - HITACHI : N5024A/11300 Series
 - DUO FAST : RNS-17481/1716CGR Series

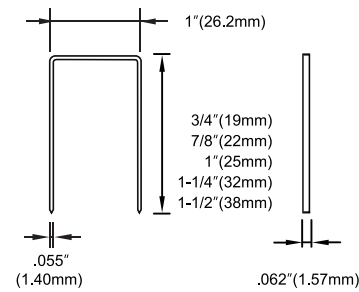

JPS38

16GA.1" Wide Crown Stapler

● **Weight :**

- 2.28 kg (5.0 lbs)

● **Dimensions :**

- H : 10-3/8" (263mm)
 - L : 14-7/16" (367mm)
 - W : 3" (76mm)

● **Staple Capacity :**

- 160 staples

● **Applications :**

- General construction works
 - Lathing
 - Sheathing



● Magnesium Body

● **Fasteners :**

- SENCO : PW150R/P Series
 - HITACHI : N5024A/11300 Series
 - DUO FAST : RNS-17481/1716CGR Series

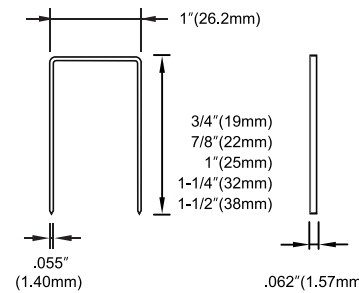

TRS25S

16GA.1" Wide Crown Stapler

● **Weight :**

- 2.43 kg (5.35 lbs)

● **Dimensions :**

- H : 9" (229mm)
 - L : 14-13/16" (376mm)
 - W : 3-17/32" (90mm)

● **Staple Capacity :**

- 160 staples

● **Applications :**

- Truss
 - Sheathing
 - Furniture framing
 - General construction works



● Magnesium Body

● Unrestricted Quick Firing trigger system.

● **Fasteners :**

- SENCO : P Series

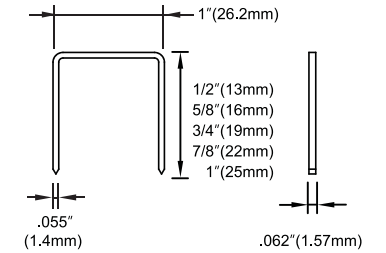

TRS25B

16GA.1" Wide Crown Stapler

● **Weight :**

- 2.41 kg (5.31 lbs)

● **Dimensions :**

- H : 9" (229mm)
 - L : 14-13/16" (376mm)
 - W : 3-17/32" (90mm)

● **Staple Capacity :**

- 160 staples

● **Applications :**

- Truss
 - Sheathing
 - Furniture framing
 - General construction works



● Magnesium Body

● Unrestricted Quick Firing trigger system.

● **Fasteners :**

- BOSTITCH : BCS(16S2) Series

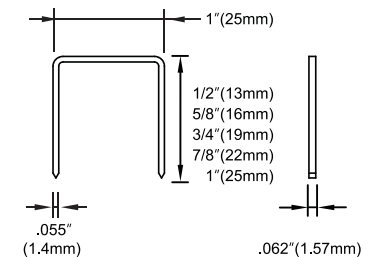

TRS38S

16GA.1" Wide Crown Stapler

● **Weight :**

- 2.28 kg (5.0 lbs)

● **Dimensions :**

- H : 10-5/16" (262mm)
 - L : 14-1/4" (362mm)
 - W : 3" (76mm)

● **Staple Capacity :**

- 160 staples

● **Applications :**

- Lathing & Insulation
 - Construction
 - Wooden working-furniture
 - Box Assembly



● Magnesium Body

● Unrestricted Quick Firing trigger system.

● **Fasteners :**

- SENCO : PW/P Series
 - HITACHI : N5024A/11300 Series
 - DUO FAST : RNS-17481/1716CGR Series

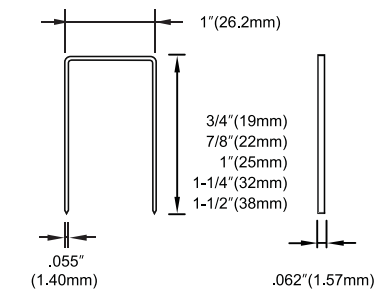

JS440K

18GA.1/4" Narrow Crown Stapler

● **Weight :**

- 2.18 kg(4.81 lbs)

● **Dimensions :**

- H : 9-9/16" (242mm)
 - L : 12-3/16" (309mm)
 - W : 4" (101mm)

● **Staple Capacity :**

- 168 staples

● **Applications :**

- Sheathing
 - Sub-flooring
 - Decking & Furniture
 - Pallet & Box Assembly
 - Furniture Framing



● **Fasteners :**

- 美特 : 440K

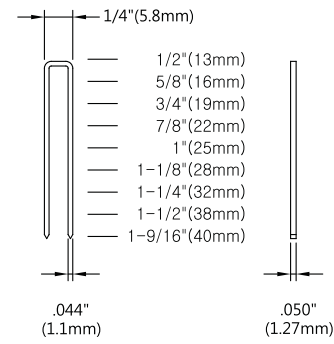

722

18GA.0.34" Crown Stapler

● **Weight :**

- 1.2 kg(2.65 lbs)

● **Dimensions :**

- H : 7-1/16" (179mm)
 - L : 9-1/2" (242mm)
 - W : 2-3/8" (60mm)

● **Staple Capacity :**

- 92 staples

● **Applications :**

- Furniture Manufacturing
 - Upholstery & Bedding



● **Fasteners :**

- MAX : TA-35A/722M

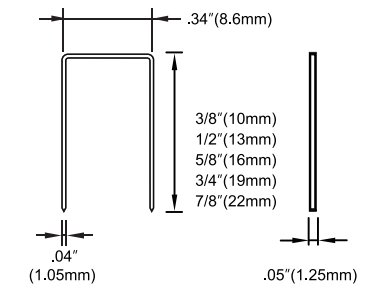

S740/18

18GA.0.34" Medium Crown Stapler

● **Weight :**

- 1.94 kg(4.28 lbs)

● **Dimensions :**

- H : 10-5/16" (262mm)
 - L : 14-5/8" (372mm)
 - W : 3-1/16" (78mm)

● **Staple Capacity :**

- 200 staples

● **Applications :**

- Interior construction
 - Upholstered furniture
 - Wooden packaging



● **Fasteners :**

- BEA : 92/40-722C
 - KOCAMAZ KT92

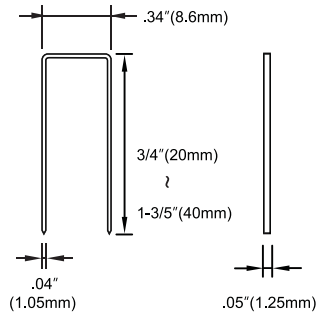

422

20GA.0.20" Crown Stapler

● **Weight :**

- 1.2 kg(2.65 lbs)

● **Dimensions :**

- H : 7-1/16" (179mm)
 - L : 9-1/2" (242mm)
 - W : 2-3/8" (60mm)

● **Staple Capacity :**

- 100 staples

● **Applications :**

- Furniture Manufacturing
 - Upholstery & Bedding



● **Fasteners :**

- MAX : TA-35A / 422J

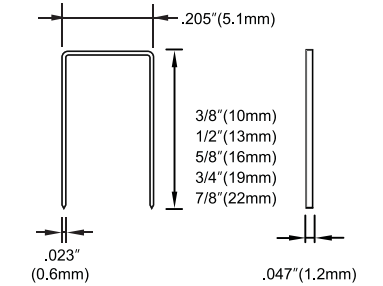

JLS38

18GA.1/4" Narrow Crown Stapler

● **Weight :**

- 1.79 kg(3.95 lbs)

● **Dimensions :**

- H : 10-3/8" (263mm)
 - L : 10" (255mm)
 - W : 3-1/16" (78mm)

● **Staple Capacity :**

- 110 staples

● **Applications :**

- Cabinets
 - Wooden Crate
 - Furniture Manufacturing



● **Fasteners :**

- BEA : NS/90 Series
 - DUO FAST : SURESHOT
 1820/1800 Series
 - SENCO : SLS/L Series

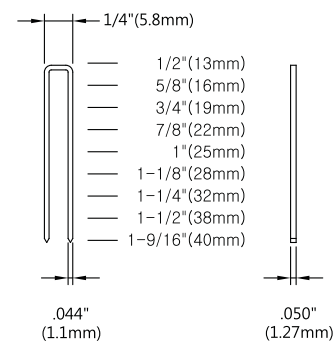

1022

20GA. 7/16" Crown Stapler

● **Weight :**

- 1.2 kg(2.65 lbs)

● **Dimensions :**

- H : 7-1/16" (179mm)
 - L : 9-1/2" (242mm)
 - W : 2-3/8" (60mm)

● **Staple Capacity :**

- 100 staples

● **Applications :**

- Furniture Manufacturing
 - Upholstery & Bedding



● **Fasteners :**

- JIT : J(10) Series
 - MAX : J(10) Series

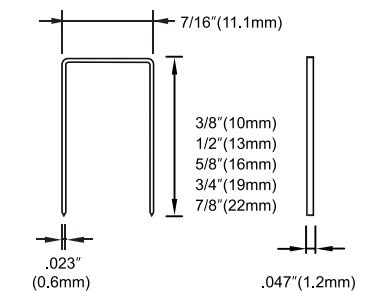

JQS65

15GA. 7/16" Crown Stapler

• **Weight :**

- 2.5 kg(5.51 lbs)

• **Dimensions :**

- H : 12-13/16" (326mm)
 - L : 14-1/4" (362mm)
 - W : 4" (101mm)

• **Staple Capacity :**

- 130 staples

• **Applications :**

- Sheathing
 - Sub-flooring
 - Furniture Framing
 - Pallet & Box Assembly



• **Fasteners :**

- SENCO : SQS 55XP

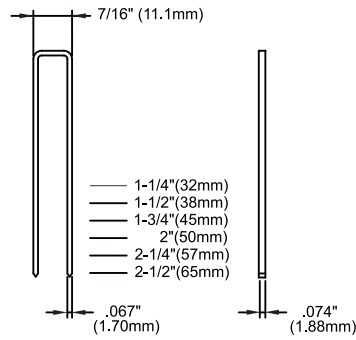

1013

20GA.7/16" Crown Stapler

• **Weight :**

- 0.88 kg(1.94 lbs)

• **Dimensions :**

- H : 5-11/16" (145mm)
 - L : 8-11/16" (228mm)
 - W : 1-7/8" (47mm)

• **Staple Capacity :**

- 100 staples

• **Applications :**

- Furniture Manufacturing
 - Upholstery & Bedding



• **Fasteners :**

- MAX : TA-20A/1013J

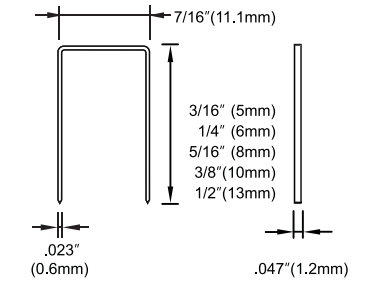

1651PW

16GA. 1" Wide Crown Stapler

• **Weight :**

- 2.45 kg(5.40 lbs)

• **Dimensions :**

- H : 10-1/4" (260mm)
 - L : 11-1/8" (283mm)
 - W : 3" (76mm)

• **Staple Capacity :**

- 150 staples

• **Applications :**

- Lathing
 - Asphalt shingles
 - Wood Framing



• **Fasteners :**

- BEA : 140&145 Fasteners Series
 - BOSTITCH - 450S2/16S2 Series

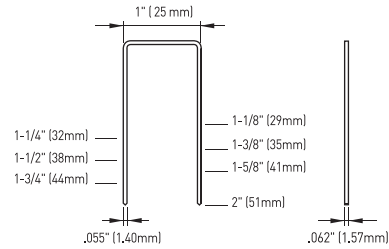

JS16-50

20GA. 1/2" Crown Stapler

• **Weight :**

- 0.90 kg(1.98 lbs)

• **Dimensions :**

- H : 6-13/16" (147mm)
 - L : 8-15/16" (227mm)
 - W : 1-7/8" (47mm)

• **Staple Capacity :**

- 95 staples

• **Applications :**

- Furniture Manufacturing
 - Upholstery & Bedding



• **Fasteners :**

- BEA : 95 Series
 - DUO FAST : SureShot
 5020/5000 Series

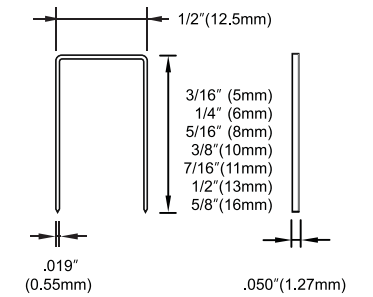

425

20GA. 0.20" Crown Stapler

• **Weight :**

- 1.2 kg(2.65 lbs)

• **Dimensions :**

- H : 7-1/16" (179mm)
 - L : 9-1/2" (242mm)
 - W : 2-3/8" (60mm)

• **Staple Capacity :**

- 100 staples

• **Applications :**

- Furniture Manufacturing
 - Upholstery
 - Bedding



• **Fasteners :**

- JIT : J(4) Series
 - MAX : J(4) Series

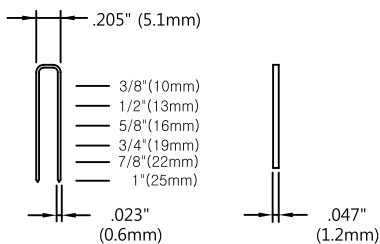

JS16-54

20GA. 3/16" Crown Stapler

• **Weight :**

- 0.90 kg(1.98 lbs)

• **Dimensions :**

- H : 5-13/16" (147mm)
 - L : 8-15/16" (227mm)
 - W : 1-7/8" (47mm)

• **Staple Capacity :**

- 95 staples

• **Applications :**

- Furniture Manufacturing
 - Upholstery & Bedding



• **Fasteners :**

- DUO FAST : SureShot
 5254/5400 Series

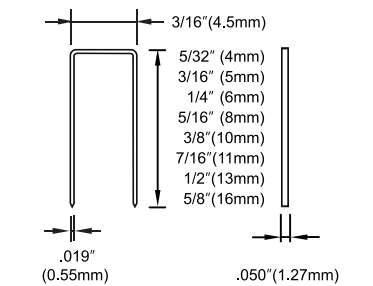

S80/16-20

20GA. 1/2" Crown Stapler

● **Weight :**

- 0.97 kg(2.13 lbs)

● **Dimensions :**

- H : 5-11/16"(145mm)
- L : 8-15/32"(215mm)
- W : 1-11/16"(43mm)

● **Staple Capacity :**

- 155 staples

● **Applications :**

- Upholstered furniture
- TV and stereo cabinets
- Automobile industry
- Bedding industry
- Wicker and rattan furniture



● **Fasteners :**

- BEA : 380/80 Series
- BOSTITCH : BA T400/BA-80 Series

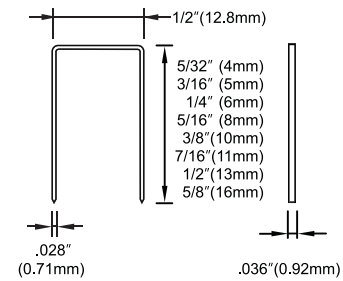

JS16-84

21GA. 1/2" Crown Stapler

● **Weight :**

- 0.86 kg(1.90 lbs)

● **Dimensions :**

- H : 5-13/16" (147mm)
- L : 8-1/16" (205mm)
- W : 1-7/8" (47mm)

● **Staple Capacity :**

- 130 staples

● **Applications :**

- Furniture Manufacturing
- Upholstery & Bedding
- Automobile industry



● **Fasteners :**

- F1B84-16 Series
- ATRO84 / OMER84

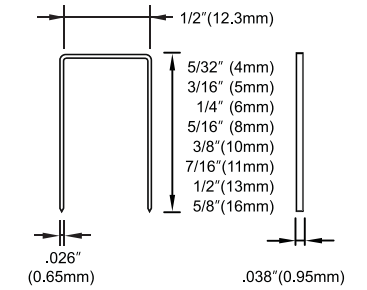

JS16-80

20GA. 1/2" Crown Stapler

● **Weight :**

- 0.90kg(1.98 lbs)

● **Dimensions :**

- H : 5-13/16" (147mm)
- L : 8-15/16" (227mm)
- W : 1-7/8" (47mm)

● **Staple Capacity :**

- 140 staples

● **Applications :**

- Furniture Manufacturing
- Upholstery & Bedding
- Automobile industry



● **Fasteners :**

- BEA : 380/80 Series
- BOSTITCH : BA T400/BA-80 Series

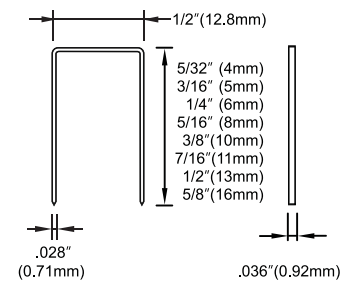

JS16-34

22GA. 3/16" Crown Stapler

● **Weight :**

- 0.88 kg(1.94 lbs)

● **Dimensions :**

- H : 5-13/16" (147mm)
- L : 8-15/16" (227mm)
- W : 1-7/8" (47mm)

● **Staple Capacity :**

- 160 staples

● **Applications :**

- Furniture Manufacturing
- Upholstery & Bedding



● **Fasteners :**

- SENCO : A Series
- DUO FAST : SureShot
3424 / 3400 Series

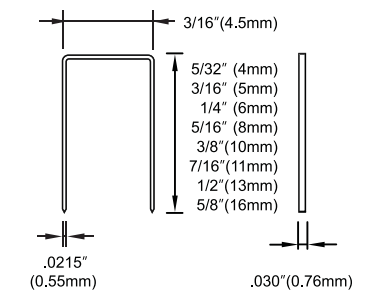

1025

20GA. 7/16" Crown Stapler

● **Weight :**

- 1.2 kg(2.65 lbs)

● **Dimensions :**

- H : 7-1/16" (179mm)
- L : 9-1/2" (242mm)
- W : 2-3/8" (60mm)

● **Staple Capacity :**

- 100 staples

● **Applications :**

- Furniture Manufacturing
- Upholstery & Bedding



● **Fasteners :**

- JIT : J(10) Series
- MAX : J(10) Series

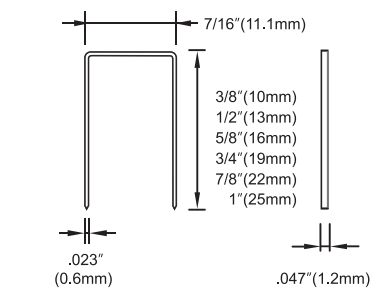

JS16-34M

22GA. 3/16" Crown Stapler

● **Weight :**

- 0.94 kg(2.07 lbs)

● **Dimensions :**

- H : 5-13/16" (147mm)
- L : 8-15/16" (227mm)
- W : 1-7/8" (47mm)

● **Staple Capacity :**

- 175 staples

● **Applications :**

- Furniture Manufacturing
- Upholstery & Bedding



● **Fasteners :**

- SENCO : A Series

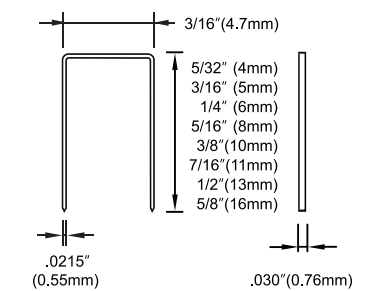

S71/16-22

22GA. 3/8" Crown Stapler

• Weight :

- 0.98 kg(2.16 lbs)

• Dimensions :

- H : 5-11/16" (145mm)
 - L : 8-15/32" (215mm)
 - W : 1-11/16" (43mm)

• Staple Capacity :

- 190 staples

• Applications :

- Cabinets
 - Automobile industry
 - Upholstered furniture
 - Bedding industry



• Fasteners :

- SENCO : SFW08/C Series
 - DUO FAST : 3118/3100 Series
 - BOSTITCH : BA T401/BA-71 Series
 - BEA : 71/71 Series

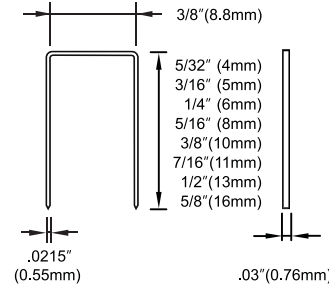

JS16-71

22GA. 3/8" Crown Stapler

• Weight :

- 0.90 kg(1.98 lbs)

• Dimensions :

- H : 5-13/16" (147mm)
 - L : 8-15/16" (227mm)
 - W : 1-7/8" (47mm)

• Staple Capacity :

- 160 staples

• Applications :

- Furniture Manufacturing
 - Upholstery & Bedding



• Fasteners :

- SENCO : SFW08/C Series
 - DUO FAST : 3118/3100 Series
 - BOSTITCH : BA T401/BA-71 Series
 - BEA : 71/71 Series

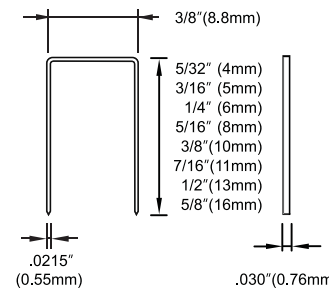

JS1414H

22GA. 3/8" Crown Stapler

• Weight :

- 0.94 kg(2.07 lbs)

• Dimensions :

- H : 5-13/16" (147mm)
 - L : 8-1/4" (232mm)
 - W : 1-7/8" (47mm)

• Staple Capacity :

- 210 staples

• Applications :

- Furniture Manufacturing
 - Upholstery & Bedding



• Fasteners :

- Haubold : KL1400 Series

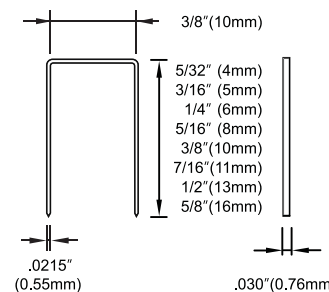

640S

23GA. 1-9/16" Micro Pinner

• Weight :

- 1.2kg (2.64 lbs)

• Dimensions :

- H : 7-17/32" (191mm)
 - L : 10-1/32" (255mm)
 - W : 1-7/8" (47mm)

• Pin Capacity :

- 200 Pins

• Fasteners :

- MAX : NF235A/23-35 Series
 - BOSTITCH : HP118K/PT1312 Series
 - SENCO : FinishPro 10/CZ Series

• Applications :

- Cabinets
 - Trim
 - Finish and Trim
 - Mirror and Picture Frames

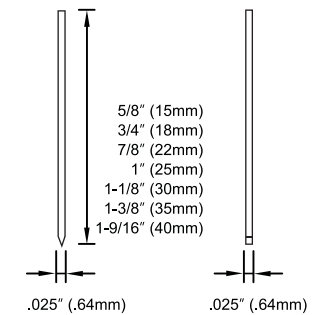

www.jitool.com

630R

23GA. 1-1/8" Micro Pinner

• Weight :

- 1.07kg (2.36 lbs)

• Dimensions :

- H : 7-3/8" (188mm)
 - L : 9-7/16" (240mm)
 - W : 1-7/8" (48mm)

• Pin Capacity :

- 200 Pins

• Fasteners :

- MAX : NF235A/23-35 Series
 - BOSTITCH : HP118K/PT1312 Series
 - SENCO : FinishPro 11/CZ Series

• Applications :

- Cabinets
 - Trim
 - Finish and Trim
 - Mirror and Picture Frames

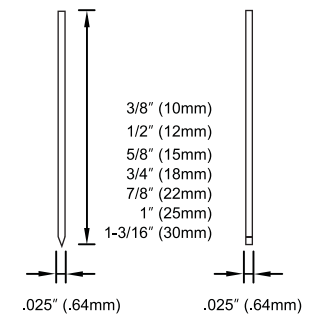

AP64RN

Air Punch

- **Weight :**
 - 1.7kg (3.75 lbs)
- **Dimensions :**
 - H : 10-19/32" (269mm)
 - L : 10-13/16" (275mm)
 - W : 3-15/32" (88mm)
- **Shank Diameter :**
 - Ø3.5 ~ Ø6.0 mm
- **Applications :**
 - Removing Nails



www.jitool.com

AP35RN

Air Punch

- **Weight :**
 - 0.83kg (1.83 lbs)
- **Dimensions :**
 - H : 8-15/32" (215mm)
 - L : 8-3/8" (214mm)
 - W : 2-11/32" (60mm)
- **Shank Diameter :**
 - Ø1.5 ~ Ø5.0 mm
- **Applications :**
 - Removing Nails



Light Weight Compressor



Stable driving "Cool-start"



Compressor motor for low voltage



The new head / Secondary cover

Oil-Less Compressor

Quieter, More efficient, Light weight



Less noise and vibrations ideal for indoor use.
No oil needed ever!